



# DataChart 6000

## Paperless Data Acquisition System

### Technical information

monarch

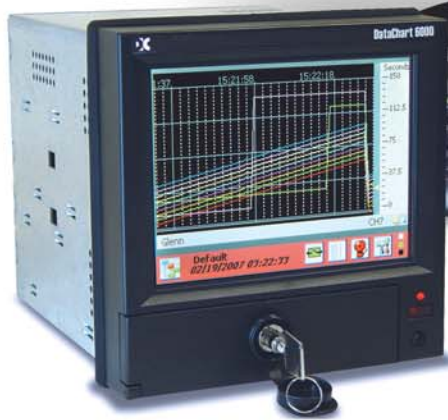
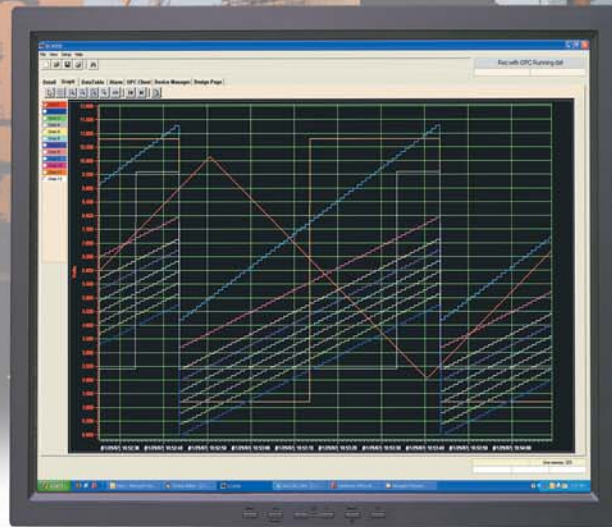
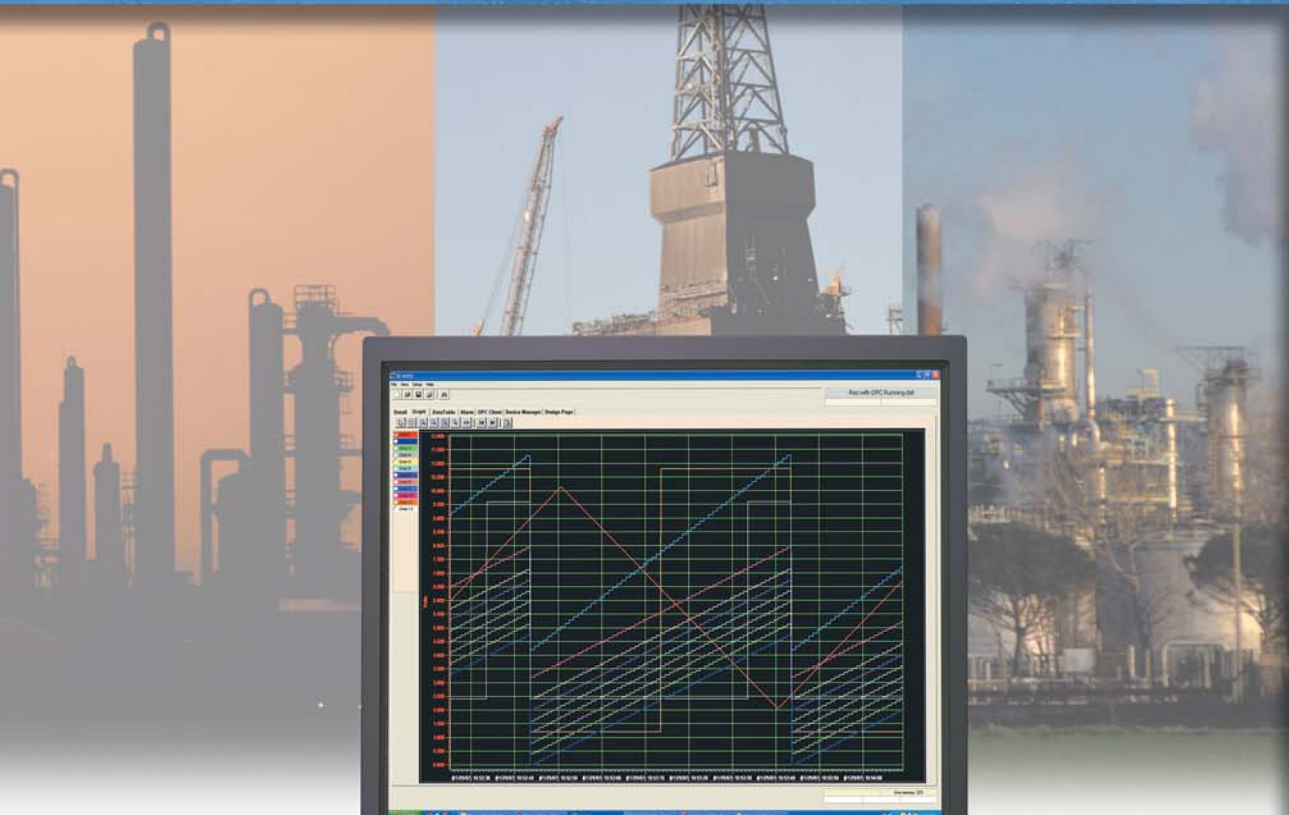

Monarch Instrument has been a pioneer in the development of paperless data acquisition systems for over 15 years. The utilization of state of the art technologies to develop intelligent, powerful and intuitive products has made Monarch Instrument's DataChart product line a global leader in paperless recording technology.

The DataChart 6000 is the most advanced paperless recording system available. It incorporates the latest in measurement, communication, interface and processing technologies to deliver unmatched performance for your data acquisition application.

*The DataChart 6000 is like no other paperless recorder available. We listened carefully to our product users and developed a device with the unique features they demanded.*



### Features

- 6 or 12 universal inputs
- Up to 4 pulse/frequency inputs
- 6 or 12 relay outputs
- Networkable using standard Ethernet Port
- 21 CFR Part 11
- 24 volt transmitter power supply
- IP65/NEMA4 compliant
- Locking media access door
- Onboard Media Drives:
  1. CompactFlash™
  2. USB (Memory stick, external drive etc.)
  3. Smart Digital (SD)
- Touch Screen Control
- Direct on screen chart annotation with integral stylus
- Infrared port
- Built in OPC server
- Built in E-mail client
- Shallow installation depth (6.5")

### Benefits

- Maximum flexibility achieved with universal inputs
- Input pulse signals directly from flow meters
- Relay outputs for control or activating external alarms
- Accessible via LAN or WEB
- Reduce cost and complexity by providing transmitter power supply
- No additional equipment needed to panel mount in harsh environments
- Media and Data can be locked and secured
- Flexibility of multiple media drives
- Intuitive icon driven touch screen interface
- Write notes and comments directly on the virtual chart for permanent storage with data
- Remote control wirelessly
- Seamlessly interfaces with third party software packages using OPC standard
- Send alarm, instantaneous data or activity information anywhere with E-mail capability
- Shallow depth allows the use of economical panels and enclosures for installation

### Common Industries

Petro Chemical  
Power  
Pharmaceutical  
Water and Waste Water

Process  
Automotive  
Steel  
Oil and Gas

Pulp and Paper  
Aerospace  
Agricultural  
Food and Dairy

Telecom  
Transportation  
Regulatory  
Medical



## Graphic User Interface and Controls

### User Interface and Control

The DC6000 utilizes a high contrast 5.6-inch color Active Matrix TFT LCD display with a rugged touch screen. Use a finger or the onboard stylus, if you prefer, to perform data entry and system navigation. The front panel is also fully compliant to IP65 for use in dusty or wet areas. An intuitive icon driven menu system guides the user through easy to follow setup and control screens. The Display Builder feature makes setting up custom screens extremely simple. Design up to 50 custom displays containing various combinations of indicator types such as horizontal and vertical bar graphs, large and small digital indicators and horizontal or vertical trends. On-screen help is available throughout the menu system to assist you during setup and use.

### Intuitive System Menu

Main Setup Menu



Windows™ Control Panel

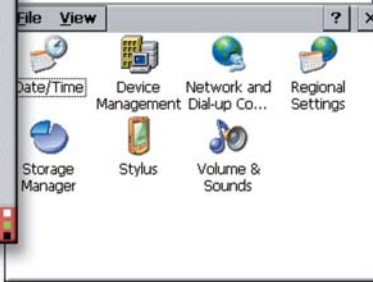

Windows™ Explorer Menu



### Custom Designable Display Screens

Display Builder

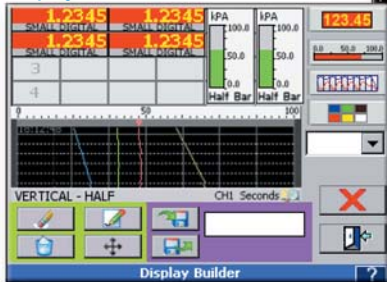

Horizontal Trend

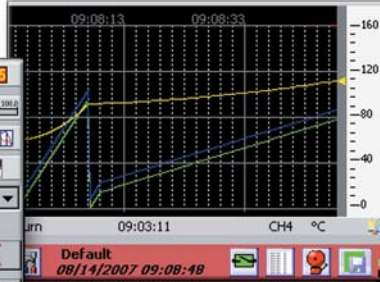

Horizontal Trend with Indicators

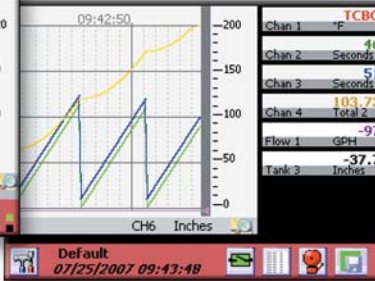

Vertical Trend

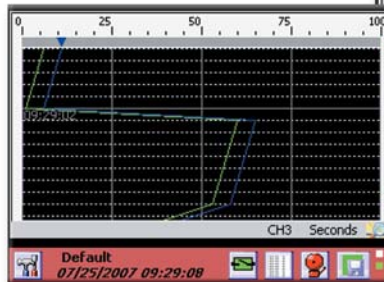

Vertical Trend with Bargraphs

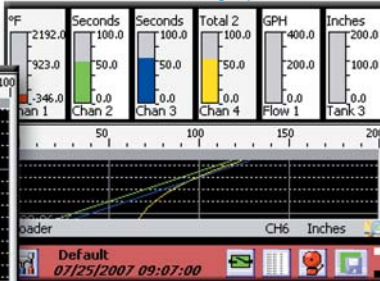

Digital Indicators with Bargraphs



Display Screen Rotation Setup

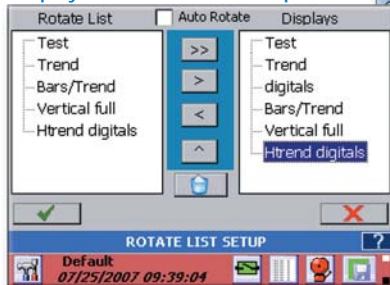

Channel Setup

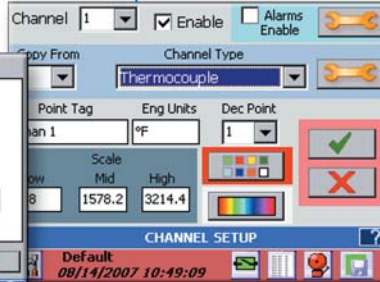

On-Screen Help

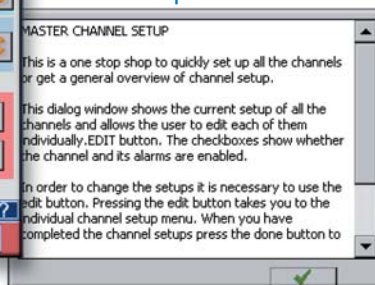

## Data Storage and Security



### Data Storage and Security

When it comes to storing data, the DC6000 is extremely flexible. Data can be stored to the non-volatile internal flash RAM or any of the available storage drives including CompactFlash™ and USB provided there is media present. Programmable record start and stop times allow the user to start and stop recording at predetermined intervals. Data may also be stored to a remote PC via Ethernet using the optional Exhibitor Software. In addition, the built in OPC Server allows any OPC compliant software client to connect to, communicate with and retrieve data. The DC6000 utilizes many layers of security to protect the integrity of your stored data. All data is stored in an encrypted binary format which prevents data tampering and maximizes compression. The front access media door is lockable to prevent unauthorized access to the internal removable storage media. There are 3 levels of password protection to prevent unauthorized entry

into critical recorder function menus. To ensure that data files are completely error free the DC6000 has a built-in rechargeable Nickel Metal Hydride battery backup system that constantly monitors the incoming power source. In the event of a power loss or power dip, the DC6000 seamlessly switches over to the internal power and begins a safe and controlled system shutdown. When power is restored the recorder immediately returns to the last state of operation. This guarantees that data files will never be corrupted by unexpected power conditions.



IP65 Front Locking Media Flap

### 21CFR Part 11

The DC6000 is fully compliant with the requirements of 21CFR Part 11. This section of the Code of Federal Regulations sets forth the guidelines for handling all aspects of electronic data storage to ensure data is secure and accurate. The DC6000 provides a password management system that allows an administrator to set multiple unique user/password combinations and assign them to one of the 3 available access levels. Each users login password can be set to automatically expire to ensure passwords are regularly updated. The DC6000 also maintains a secure, time stamped audit trail to independently record the date and time of operator entries and actions that create, modify, or delete electronic records.

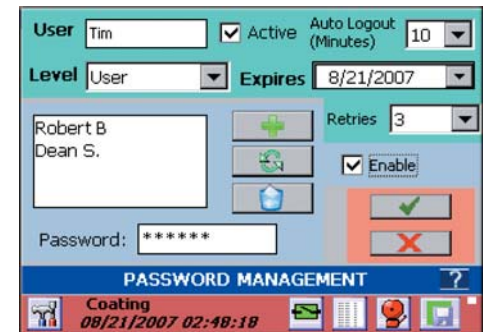

### Recording Data

Using the Record Setup menu, the user can select which channels to record, the sample storage rate, whether to record alarms and/or events, and the start/stop time and date for the record session. The location of the data file is selected in this menu along with the data file name. The user can also configure the unit to start or stop recording on an alarm level or an externally triggered input.

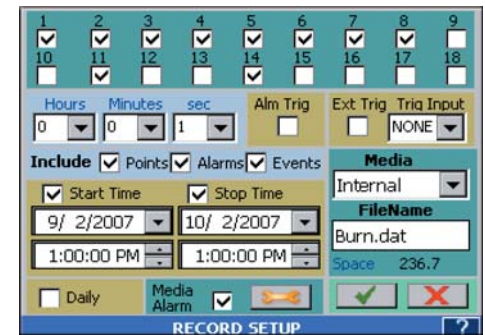

### Media Storage Locations

**Front Accessible:** (lockable)  
CompactFlash™  
USB Host (for memory stick)

**Rear Accessible:**  
USB Host  
Ethernet

**Internal:**  
128 Meg Standard  
(Larger sizes available)

### Data Storage vs. Time Guide

Record Rate	1 Channel		2 Channels		4 Channels		6 Channels		12 Channels	
	64 Mb	1Gb	64 Mb	1G	64 Mb	1G	64 Mb	1G	64 Mb	1G
<b>10/Sec.</b>	3.1 Days	49.4 Days	2.5 Days	40.8 Days	1.9 Days	30.4 Days	1.5 Days	24.2 Days	22.5 Hours	15 Days
<b>5/Sec.</b>	6.2 Days	246.9 Days	5 Days	81.6 Days	3.8 Days	60.8 Days	3 Days	48.4 Days	1.8 Days	30 Days
<b>1/Sec.</b>	30.8 Days	1.3 Years	25.5 Days	1.1 Years	19.0 Days	303.9 Days	15.1 Days	241.8 Days	9.4 Days	150 Days
<b>10 Sec.</b>	308 Days	13.5 Years	251 Days	10.6 Years	190 Days	8.0 Years	150 Days	6.4 Years	50 Days	4.1 Years
<b>1 Min.</b>	5.1 Years	81.2 Years	4.2 Years	66 Years	3.1 Years	49.9 Years	2.5 Years	39.7 Years	1.5 Years	24.6 Years
<b>10 Min.</b>	50.6 Years	811.7 Years	42 Years	666 Years	31 Years	499 Years	25 Years	397 Years	15 Years	246 Years

### Removable Media Types



USB Memory Stick

## Unique Features

### Write directly on the screen

The innate feature of handwriting notes and comments on the chart of paper recorders had been lost with the onset of video graphic recorders until the arrival of the DC6000. Using the high-resolution touch screen interface and the integral stylus you can once again make notes or comments directly on the chart. This on-screen annotation is stored within the data file directory and can be recalled and displayed on the recorder or in Exhibitor Software.



Make notes, sign files or make other graphic indications directly on the virtual chart in your own handwriting or use the built-in keyboard to type messages on the screen. Your notes are stored within the data file directory for future review.

### Powerful Math Package

The onboard math package is extremely powerful. It allows the user to input complex polynomial equations using constants, custom functions and variable inputs obtained from live channels. The resultant information can be displayed and recorded as a real time channel.

Using the intuitive Calculated Channel Setup menu the user enters in the formula and can perform a test to make sure the formula is accurate.

#### Formula Entry Screen

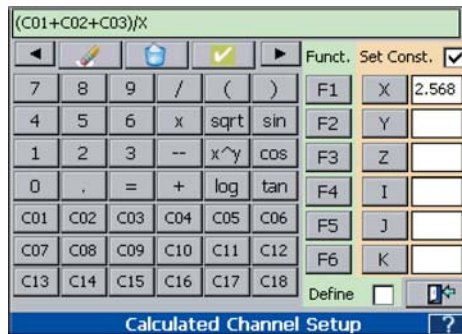

#### Formula Test Screen

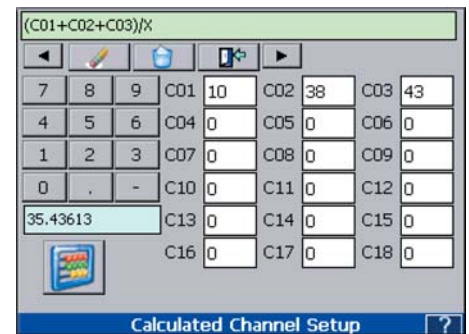

### Unique Sounds

Unique .wav files may be uploaded and played through the internal speaker to alert of specific types of alarms. Use any .wav file, even customize your own spoken word announcements. In areas where there is a high level of ambient noise the alarm .wav files can be output to a P.A. system or amplified speakers via the rear mounted audio connector. Each alarm setpoint can have a unique sound file associated with it. In the Alarm Setup menu simply select the .wav file you want to play when the alarm is active.

Play unique sound files for each alarm by simply selecting the file you want to play when you set up the alarm.



### Remote Control

The Remote Control feature extends the graphic user interface of the DC6000 directly onto your local PC. Use remote control and your desktop PC's mouse and keyboard to view real time data, change settings, start and stop recording or virtually anything else you can do with the recorders touch screen. Across the plant or across the planet, remote control empowers you with virtual presence.

Remote control brings a virtual real time graphic display from your remotely located DC6000 directly to your Windows™ Desktop.

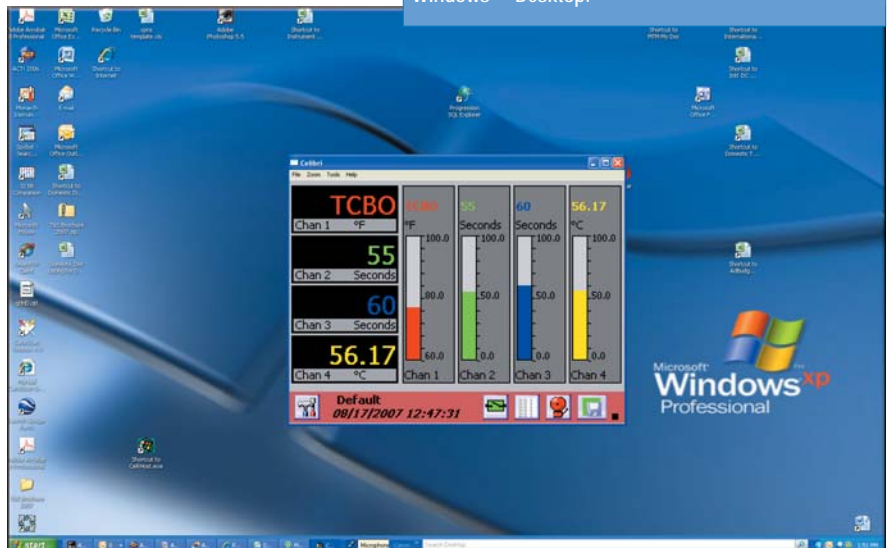

Exhibitor Software is an extremely powerful set of tools that compliments the DC6000 and other OPC compliant devices. Incorporating functions to simplify data management via searching, reviewing, printing, or exporting historic data, Exhibitor Software allows real-time monitoring and recording independently as well, while historic recording is not affected. Also featured is the OPC Client which enables the user to build custom screens selecting various display elements and data from multiple OPC Servers, including devices other than DC6000's. (Windows™ XP/2000 Compatible).

### Network Overview

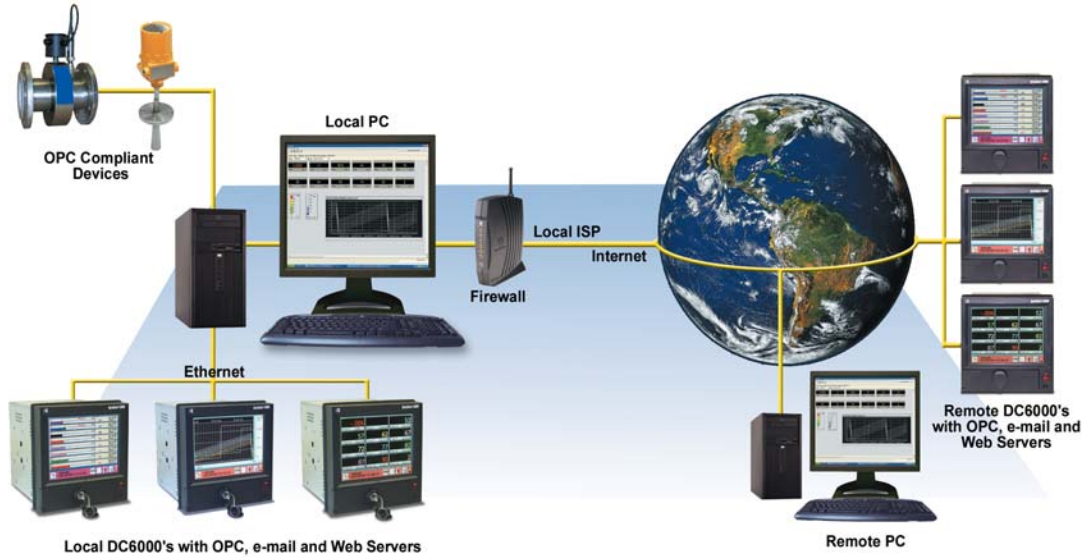

### Customizable Real-Time View

Use Exhibitor's design page features to create custom real-time display projects that can be saved and recalled with a click of the mouse. Create bar graphs, digital panel meters, thermometers or trend screens from live data coming from any DC6000 or other OPC compliant device accessible on the network. Using the OPC Device Manager, Exhibitor allows you to connect to OPC Servers anywhere there is a network connection. A user definable list of data is then accessible by the Design Page, where customized Real-Time Displays are built using the user friendly Graphic User Interface. To place items, simply point, click, and drag. Save your project for future use and the next time it is opened all servers are automatically connected and data will begin displaying immediately. Go one step further, and record real time data to your PC.

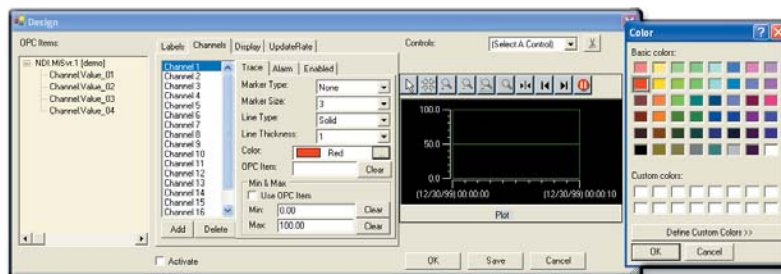
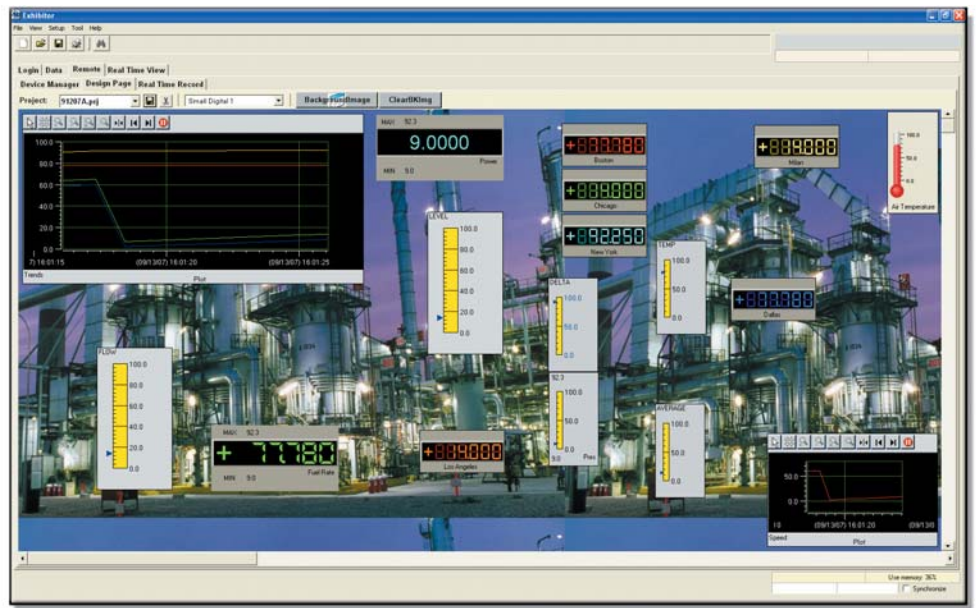

Select the type of control to be displayed then customize its size, color and location.

## Exhibitor Software

### Graphical Review

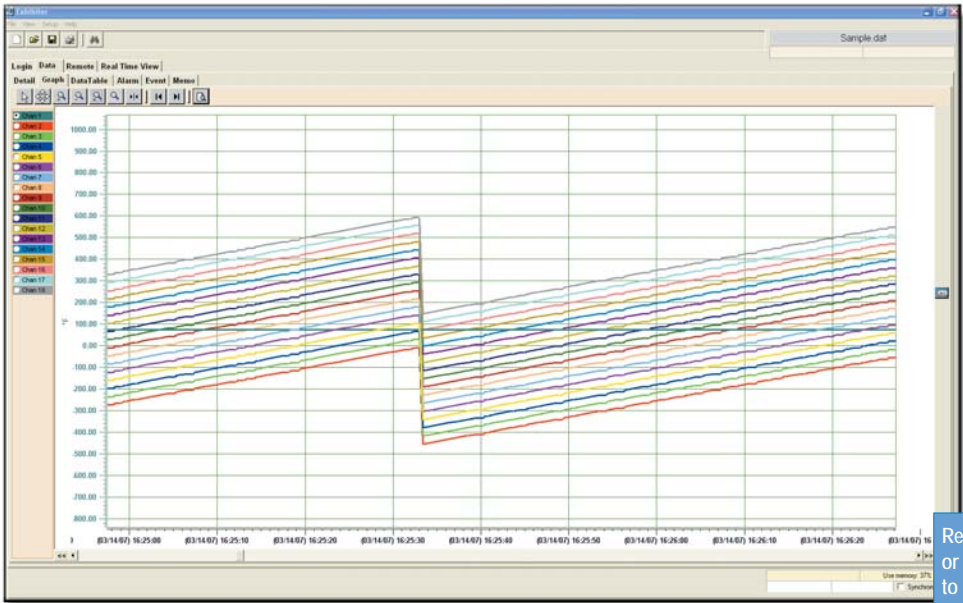

The composite graphical view can display all inputs and calculated data from a particular recording session. The user is able to manipulate the graph to make it easy to see interaction between recorded channels, turn channels off and on, change color schemes, expand, compress, zoom, and print.

Individual channels can be displayed for detailed analysis. There is a summary function for the individual channels which provides minimum, maximum, averages and time and date for the records. The same analysis tools used for the multi-channel graph are used to scroll through data, zoom, review and expand the single channel graphs.

Review all channels simultaneously or select only the channels you wish to display.

### Tabular Data Review

Time	Chan1	Chan2	Chan3	Chan4	Chan5	Chan6	Chan7	Chan8	Chan9	Chan10	Chan11	Chan12	Chan13	Chan14	Chan15	Chan16	Chan17	Chan18	Chan19
3:14:0007 16:24:22:300	74.8	88	53	58	63	68	73	78	83	88	93	98	103	108	113	118	123	128	
3:14:0007 16:24:22:400	75	89	54	59	64	69	74	79	84	89	94	99	104	109	114	119	124	129	
3:14:0007 16:24:22:500	74.8	89	54	59	64	69	74	79	84	89	94	99	104	109	114	119	124	129	
3:14:0007 16:24:23:000	75	89	54	59	64	69	74	79	84	89	94	99	104	109	114	119	124	129	
3:14:0007 16:24:23:100	74.8	89	54	59	64	69	74	79	84	89	94	99	104	109	114	119	124	129	
3:14:0007 16:24:23:200	74.8	89	54	59	64	69	74	79	84	89	94	99	104	109	114	119	124	129	
3:14:0007 16:24:23:300	74.8	89	54	59	64	69	74	79	84	89	94	99	104	109	114	119	124	129	
3:14:0007 16:24:23:400	74.8	89	54	59	64	69	74	79	84	89	94	99	104	109	114	119	124	129	
3:14:0007 16:24:23:500	74.8	89	54	59	64	69	74	79	84	89	94	99	104	109	114	119	124	129	
3:14:0007 16:24:24:000	74.8	89	54	59	64	69	74	79	84	89	94	99	104	109	114	119	124	129	
3:14:0007 16:24:24:100	74.8	89	54	59	64	69	74	79	84	89	94	99	104	109	114	119	124	129	
3:14:0007 16:24:24:200	74.8	89	54	59	64	69	74	79	84	89	94	99	104	109	114	119	124	129	
3:14:0007 16:24:24:300	74.8	89	54	59	64	69	74	79	84	89	94	99	104	109	114	119	124	129	
3:14:0007 16:24:24:400	74.8	89	54	59	64	69	74	79	84	89	94	99	104	109	114	119	124	129	
3:14:0007 16:24:24:500	74.8	89	54	59	64	69	74	79	84	89	94	99	104	109	114	119	124	129	
3:14:0007 16:24:25:000	74.8	89	54	59	64	69	74	79	84	89	94	99	104	109	114	119	124	129	
3:14:0007 16:24:25:100	74.8	89	54	59	64	69	74	79	84	89	94	99	104	109	114	119	124	129	
3:14:0007 16:24:25:200	74.8	89	54	59	64	69	74	79	84	89	94	99	104	109	114	119	124	129	
3:14:0007 16:24:25:300	74.8	89	54	59	64	69	74	79	84	89	94	99	104	109	114	119	124	129	
3:14:0007 16:24:25:400	74.8	89	54	59	64	69	74	79	84	89	94	99	104	109	114	119	124	129	
3:14:0007 16:24:25:500	74.8	89	54	59	64	69	74	79	84	89	94	99	104	109	114	119	124	129	
3:14:0007 16:24:26:000	74.8	89	54	59	64	69	74	79	84	89	94	99	104	109	114	119	124	129	
3:14:0007 16:24:26:100	74.8	89	54	59	64	69	74	79	84	89	94	99	104	109	114	119	124	129	
3:14:0007 16:24:26:200	74.8	89	54	59	64	69	74	79	84	89	94	99	104	109	114	119	124	129	
3:14:0007 16:24:26:300	74.8	89	54	59	64	69	74	79	84	89	94	99	104	109	114	119	124	129	
3:14:0007 16:24:26:400	74.8	89	54	59	64	69	74	79	84	89	94	99	104	109	114	119	124	129	
3:14:0007 16:24:26:500	74.8	89	54	59	64	69	74	79	84	89	94	99	104	109	114	119	124	129	
3:14:0007 16:24:27:000	74.8	89	54	59	64	69	74	79	84	89	94	99	104	109	114	119	124	129	
3:14:0007 16:24:27:100	74.8	89	54	59	64	69	74	79	84	89	94	99	104	109	114	119	124	129	
3:14:0007 16:24:27:200	74.8	89	54	59	64	69	74	79	84	89	94	99	104	109	114	119	124	129	
3:14:0007 16:24:27:300	74.8	89	54	59	64	69	74	79	84	89	94	99	104	109	114	119	124	129	
3:14:0007 16:24:27:400	74.8	89	54	59	64	69	74	79	84	89	94	99	104	109	114	119	124	129	
3:14:0007 16:24:27:500	74.8	89	54	59	64	69	74	79	84	89	94	99	104	109	114	119	124	129	
3:14:0007 16:24:28:000	74.8	89	54	59	64	69	74	79	84	89	94	99	104	109	114	119	124	129	
3:14:0007 16:24:28:100	74.8	89	54	59	64	69	74	79	84	89	94	99	104	109	114	119	124	129	
3:14:0007 16:24:28:200	74.8	89	54	59	64	69	74	79	84	89	94	99	104	109	114	119	124	129	
3:14:0007 16:24:28:300	74.8	89	54	59	64	69	74	79	84	89	94	99	104	109	114	119	124	129	
3:14:0007 16:24:28:400	74.8	89	54	59	64	69	74	79	84	89	94	99	104	109	114	119	124	129	
3:14:0007 16:24:28:500	74.8	89	54	59	64	69	74	79	84	89	94	99	104	109	114	119	124	129	
3:14:0007 16:24:29:000	74.8	89	54	59	64	69	74	79	84	89	94	99	104	109	114	119	124	129	
3:14:0007 16:24:29:100	74.8	89	54	59	64	69	74	79	84	89	94	99	104	109	114	119	124	129	
3:14:0007 16:24:29:200	74.8	89	54	59	64	69	74	79	84	89	94	99	104	109	114	119	124	129	
3:14:0007 16:24:29:300	74.8	89	54	59	64	69	74	79	84	89	94	99	104	109	114	119	124	129	
3:14:0007 16:24:29:400	74.8	89	54	59	64	69	74	79	84	89	94	99	104	109	114	119	124	129	
3:14:0007 16:24:29:500	74.8	89	54	59	64	69	74	79	84	89	94	99	104	109	114	119	124	129	
3:14:0007 16:24:30:000	74.8	89	54	59	64	69	74	79	84	89	94	99	104	109	114	119	124	129	
3:14:0007 16:24:30:100	74.8	89	54	59	64	69	74	79	84	89	94	99	104	109	114	119	124	129	
3:14:0007 16:24:30:200	74.8	89	54	59	64	69	74	79	84	89	94	99	104	109	114	119	124	129	
3:14:0007 16:24:30:300	74.8	89	54	59	64	69	74	79	84	89	94	99	104	109	114	119	124	129	
3:14:0007 16:24:30:400	74.8	89	54	59	64	69	74	79	84	89	94	99	104	109	114	119	124	129	
3:14:0007 16:24:30:500	74.8	89	54	59	64	69	74	79	84	89	94	99	104	109	114	119	124	129	
3:14:0007 16:24:31:000	74.8	89	54	59	64	69	74	79	84	89	94	99	104	109	114	119	124	129	
3:14:0007 16:24:31:100	74.8	89	54	59	64	69	74	79	84	89	94	99	104	109	114	119	124	129	
3:14:0007 16:24:31:200	74.8	89	54	59	64	69	74	79	84	89	94	99	104	109	114	119	124	129	
3:14:0007 16:24:31:300	74.8	89	54	59	64	69	74	79	84	89	94	99	104	109	114	119	124	129	
3:14:0007 16:24:31:400	74.8	89	54	59	64	69	74	79	84	89	94	99	104	109	114	119	124	129	
3:14:0007 16:24:31:500	74.8	89	54	59	64	69	74	79	84	89	94	99	104	109	114	119	124	129	
3:14:0007 16:24:32:000	74.8	89	54	59	64	69	74	79	84	89	94	99	104	109	114	119	124	129	
3:14:0007 16:24:32:100	74.8	89	54	59	64	69	74	79	84	89	94	99	104	109	114	119	124	129	
3:14:0007 16:24:32:200	74.8	89	54	59	64	69	74	79	84	89	94	99							

## Specifications

### General

**Input Resolution:** 0.0015% of full scale, 16 bit unless otherwise stated  
**Input Impedance:** >1 Mohm  
**Input Channels:** 6 or 12 direct input plus 6 additional calculated channels  
**Maximum Input:** 50Vdc  
**Isolation:** Channel to Channel: 350Vdc or RMS AC  
 Channel to Chassis: 2000 Vdc or RMS AC  
 Isolation category II: Pollution Degree 2  
**Measurement Rate:** 10 times per second on all direct input channels  
**Common Mode Noise Rejection:** >100dB, 50/60 Hz, filter enabled  
**Normal Mode Noise Rejection:** >50dB at 50/60 Hz, filter enabled  
**Math Functions:** Fully programmable +, -, x, /, square root, sine, cosine, tangent, log, totalization, powers, averages, conditional logic; AND, NOT, OR, +, >, <, gated timers. Can use live channels in calculation. Can define 6 constants and 6 functions per channel.

### Analog Inputs

**DC Voltage:** +/-125mV, +/-250mV, +/-500mV, +/-1.00V, +/-3.0V, +/-6.0V, +/-12.0V, +/-24.0V  
**Accuracy:** Ranges to 1V +/-0.06%, Ranges > 1V +/-0.1%

**DC Current:** 4-20mA, 0-20mA, 10-50mA  
**Accuracy:** +/-0.15% using external 50 ohm 0.1% 1/4 watt shunt

### Thermocouple (Per ITS90)

**Resolution:** 0.1C, thermocouple burnout detection: Automatic  
**Reference junction compensation accuracy:** +/-2.5 °C (0 °C to 50 °C)

Type	Range (°C) Accuracy (°C)	Range (°F) Accuracy (°F)
J	-210 to -100°C +/-2.5 °C	-340 to -150 °F +/- 5 °F
	-100 to 1200 °C +/- 1.5 °C	-150 to 2190 °F +/- 3 °F
K	-270 to -100 °C +/- 2.5 °C	-450 to -150 °F +/- 5 °F
	-100 to 1372 °C +/- 1.5 °C	-150 to 250 °F +/- 3 °F
T	-270 to -100 °C +/- 2.5 °C	-450 to -150 °F +/- 5 °F
	-100 to 400 °C +/- 1.5 °C	-150 to 750 °F +/- 3 °F
E	-270 to -100 °C +/- 2.5 °C	-450 to -150 °F +/- 5 °F
	-100 to 1000 °C +/- 1.5 °C	-150 to 1832 °F +/- 3 °F
N	-270 to -100 °C +/- 2.5 °C	-450 to -150 °F +/- 5 °F
	-100 to 1300 °C +/- 1.5 °C	-150 to 2372 °F +/- 3 °F
S	-50 to 1768 °C +/- 3 °C	-58 to 3200 °F +/- 6 °F
B	0 to 1820 °C +/- 4 °C	32 to 3300 °F +/- 7 °F

### RTD

**Base Accuracy:** 0.2% or 0.5 °C (1 °F). **Resolution:** 0.1 °C  
 2 or 3 wire connection. Cable compensation to +50 ohm. Open and short circuit detection.

Type	Range °C	Range °F
100 ohm Plt. 385	-220 to 85 °C	-364 to 1560 °F
100 ohm Plt. 392	-180 to 820 °C	-292 to 1500 °F
200 ohm Plt. 385	-220 to 400 °C	-364 to 750 °F
200 ohm Plt. 392	-180 to 400 °C	-292 to 750 °F
100 ohm Ni.	-70 to 300 °C	-94 to 570 °F
120 ohm Ni.	-70 to 300 °C	-94 to 570 °F
1000 ohm Ni.	-60 to 209 °C	-76 to 408 °F
10 ohm Cu.	-70 to 170 °C	-94 to 338 °F*

\*0.5% +/- 0.5 °C

### Frequency inputs (2 or 4 channels)

**Range:** 0 to 5,000Hz all channels, 0 to 10,000Hz 1 channel  
**Accuracy:** 0.005% +/- 1 digit

### Recording

**Recording Rates:** User programmable from 10 samples per second to 1 sample every 24 hours  
**Data Format:** Proprietary encrypted format, User file naming  
**Data Storage Capacity:** Data stored in non-volatile RAM and recorded automatically to:  
**Removable media types:**  
 CompactFlash™ or USB drive to 4 GB  
**Internal media type:**  
 SD card (secure digital) to 4 GB

**File Types:** Data files, alarm and event files, configuration files, language files, multiple files of different names on a single disk.

### Display

**Type:** Color CCFL backlit Active Matrix TFT Liquid Crystal Display  
**Size:** 5.6 inch diagonal, **Resolution:** 320 (W) x 240 (H) pixels  
**Interface:** Resistive analog touch screen control  
**Display Builder:** Allows user to create custom displays  
**Display Modes:** Graphic trending (vertical or horizontal), Bar Graphs (vertical or horizontal), Digital Meter (large or small), Alphanumeric Alarm and Event log  
**Virtual Chart Speed:** Programmable from 0.5 inch/hour to 600 inches/hour (10 mm/hr to 10,000 mm/hr)  
**Display Windows:** Time/Date, Graphics (bars, large digital, trends) Disk Status, System Status, Menu Button Bar, Unit Identification, Alarms/Events

### Communications

**Network:** 10/100 Base T Ethernet per 802.3, RJ45 connection standard  
**Servers:** Webserver supports http and ftp protocols, OPC server, Modbus over Ethernet server  
**Serial:** Isolated RS485/RS232 Modbus Interface (option)

### Power

**Requirements:** 100 to 240 Vac, 50/60Hz. 35 VA max. Optional 24 Vdc +/-15%  
**Power Fail Protection:** Programmed parameters stored in non-volatile memory. Clock battery backed. Internal battery backup provides orderly shutdown and the ability to survive brownouts and short blackouts (<20 seconds)  
**Power Output:** Optional isolated 24Vdc @ 120mA output

### Input/Output

**Digital I/O:** 6 or 12 relay outputs, Form A (normally open SPST contacts) rated at 200 Vdc @ 0.5A Max, 2 digital control inputs +5 to +12Vdc @ 20mA (optional), Control inputs may be used for record start/stop, alarm acknowledge and channel reset functions

### Safety and Environmental

**Operating Range:** 0 °C to 50 °C, 10% to 80% RH non-condensing  
**Protection:** IP65 when mounted in panel  
**Safety:** Meets the requirements of EN61010-1 when installed in accordance with the instructions in the manual.  
**UL and cUL:** Pending  
**EMC:** Meets the requirements of EN61326:2003 and CE directive 89/336/EEC.  
**Weight:** Approximately 7 lbs. (3.17 kg) - weight will vary depending on options installed

### Rear Panel

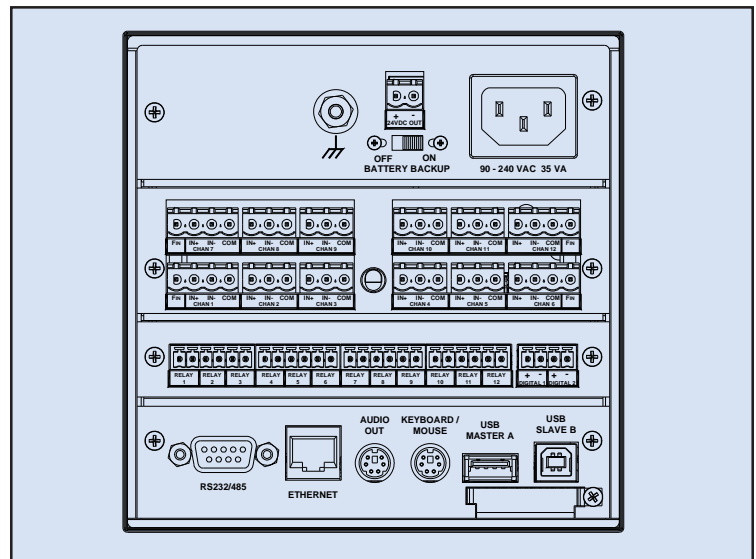



## Ordering Information

### Standard DC6000 Features:

5.6" color QVGA TFT LCD display with touch screen and integral stylus  
 CompactFlash™ Drive (Front), USB thumb drive port (Front)  
 USB master (rear), USB slave (Rear), Internal memory  
 Mouse/keyboard connection (Rear)  
 Audio: Line in, Line out, Microphone (Rear)  
 RJ45 Ethernet port (Rear)  
 NEMA 4/IP65 Front Bezel with locking media drive door

### Determining model number configuration

To specify your DataChart™ 6000, select desired options and enter the appropriate selection in the boxes below. Example model number: DC6-1-06-1-0-1-0

### Select options

Build model #: **DC6**

#### Input Power

- 1 100 to 240 Vac 50/60Hz / 125 Vdc with cable and plug
- 2 12 - 24 Vdc
- 3 100 to 240 Vac 50/60Hz / 125 Vdc with Screw Terminals

#### Input Signals

- 06 6 Total: 4 (V, I, TC, RTD), 2 (V, I, TC, RTD, Frequency)
- 12 12 Total: 8 (V, I, TC, RTD), 4 (V, I, TC, RTD, Frequency)

#### Output Options

- 0 None
- 1 6 Form A relay contacts 0.5 Amp @ 200Vdc, 2 Control Inputs
- 2 12 Form A relay contacts 0.5 Amp @ 200Vdc, 2 Control Inputs

#### Serial Communications

- 0 None
- 1 RS232/485 (9 pin "D" shell connector)

#### Transmit Power Supply

- 0 None
- 1 24 Vdc, 100mA auxiliary output

#### Internal Memory

- 0 128 Megabyte
- 1 512 Megabyte
- 2 1 Gigabyte
- 3 2 Gigabyte

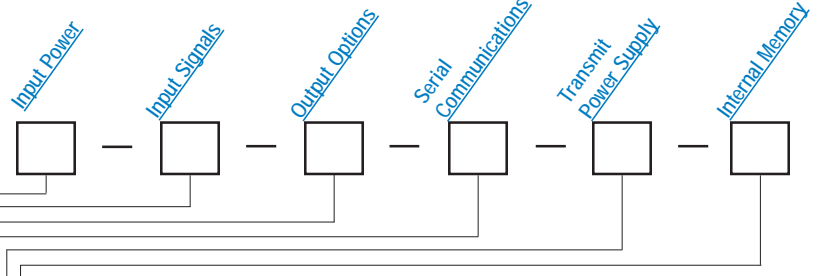

### Field Upgradeable Options

Part No.	Description
6CH-ADD	6 Channel input module with connectors
6-FormA	6 Form A relay output module with connectors
12-FormA	12 Form A relay output module with connectors
24-TP	24 volt transmitter power supply module with connector

### Accessories

Part No.	Description
Exhibitor	Windows XP compatible software program
NIST 6000	N.I.S.T. traceable certificate of calibration with documentation
21CFR CS	21CFR p.11 Compliance Statement
21CFR CDP	21CFR p.11 Compliance Document Package
MAS50R	50 ohm external shunt resistor, 0.1% accuracy
CC-8	Padded nylon carrying case with shoulder strap
CFCR	Compact Flash Card Reader with USB cable
Audio Splitter	Splitter for audio port (includes cables)
Keyboard Splitter	Splitter for keyboard and mouse port (includes cable)
Stylus Pak	3 pack of stylus'
Keys	Replacement media flap key (pair)

### Compact Flash Memory Cards

Part No.	Capacity
MC256MB	256 Megabyte
MC512MB	512 Megabyte
MC1024MB	1 Gigabyte
MC2048MB	2 Gigabyte

### Dimensions

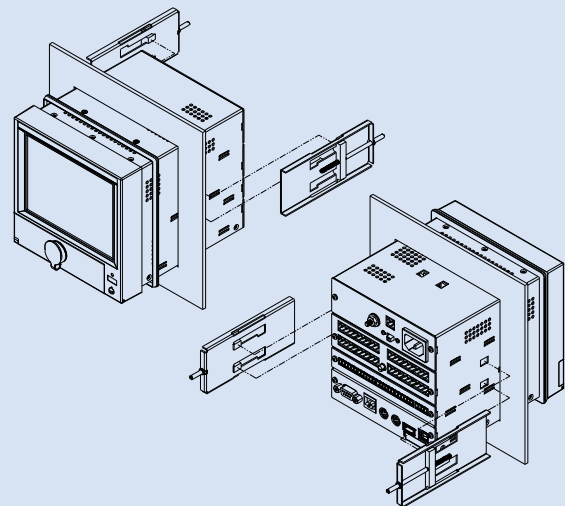
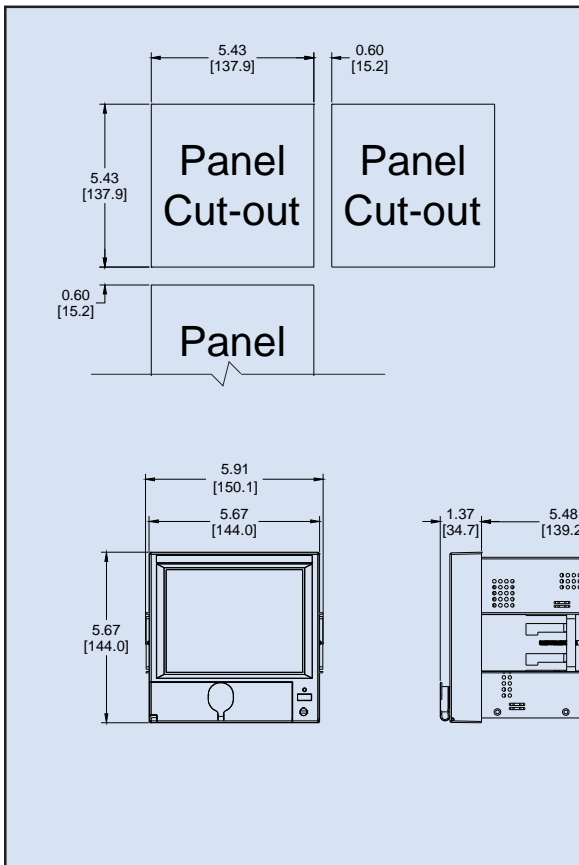

# CORPORATE HISTORY

## *Innovation in Instrumentation*

Monarch International, Inc. was founded in 1977 as a sales and service organization for a diverse range of instrumentation. In 1982, the Monarch Instrument Division was established to manufacture and market the first microprocessor based portable tachometers.



Monarch International's 30,000 square-foot facility in Amherst, New Hampshire, U.S.A.

With the addition of new models of tachometers and the introduction of the Nova-Strobe Series of portable stroboscopes, Monarch rapidly became the worlds largest supplier of rotational speed measuring instrumentation and stroboscopic inspection equipment.

In 1992, Monarch introduced the DataChart Paperless Recorder. Today, we offer a wide range of technical capabilities and competitive pricing throughout the DataChart product line to include color touchscreens and multi-channel recorders.

**"Innovation in Instrumentation"** is the Monarch design philosophy and in recent years we have introduced state-of-the-art products:

- ▶ **Pocket Laser Tachometer**
- ▶ **PALM STROBE x**
- ▶ **Nova-Strobe DBx Stroboscope**
- ▶ **Examiner 1000 Vibration Meter**
- ▶ **DataChart 1250 Paperless Recorder**

Monarch Instrument remains committed to innovations and quality in sales, customer service and manufacturing.



Thank you from all of us at Team Monarch

Our full service sales force and world-wide distribution force stands ready to answer purchase and applications questions. Please feel free to contact us via our toll free telephone line, website, e-mail, fax or surface mail. We offer a comprehensive line of precision products and calibration services, all with the convenience of the Internet.



Monarch Instrument also manufactures a full line of proactive maintenance and monitoring instruments. Please visit [www.monarchinstrument.com](http://www.monarchinstrument.com) for more information.



**ISO 2000  
CERTIFIED**



Proudly distributed by:

**Monarch Instrument**  
15 Columbia Drive  
Amherst, NH 03031

ph: (603) 883-3390  
fx: (603) 886-3300  
[www.monarchinstrument.com](http://www.monarchinstrument.com)  
email: [sales@monarchinstrument.com](mailto:sales@monarchinstrument.com)